

# C9174TN1D



<b>Product Family</b>	Refrigerator
<b>Installation</b>	Built-in
<b>Category</b>	Bottom Mount
<b>Built-in niche</b>	178
<b>Reference width</b>	Until 60 cm
<b>Reference height</b>	160 - 200 cm
<b>Sistema Total No - Frost</b>	Total
<b>Cooling type</b>	Total No Frost - Double Cooling system
<b>Defrost</b>	Automatic
<b>Hinge type</b>	Sliding
<b>Kitchen panel</b>	Not supplied
<b>Hinge position</b>	Right
<b>Reversible door</b>	Yes
<b>EAN code</b>	8017709359560



## Aesthetics



<b>Interior in recycled material</b>	Yes	<b>Logo</b>	Silk screen
<b>Aesthetic</b>	Universale	<b>Door shelves profile color</b>	Silver
<b>Colour</b>	White	<b>Drawers profile color</b>	Silver
<b>Material</b>	Metal sheet	<b>Color of glass shelf profile</b>	Silver
<b>Side material</b>	Steel	<b>Display</b>	LCD Touch
<b>Side colour</b>	White	<b>Display position</b>	Interno (sul Top)

## Refrigerator compartment features



<b>No. of adjustable shelves</b>	3	<b>Type of crisper/vegetable drawers cover</b>	Glass
<b>Number of fruit and vegetables drawers</b>	2	<b>No. of lights refrigerator compartment</b>	3
<b>Shelves material</b>	Glass	<b>Internal light in fridge</b>	Yes
<b>Type of crisper/vegetable drawers cover</b>	On sliding rails	<b>Type of internal light (fridge)</b>	LED
<b>Crisper Cover</b>	Yes		

## Refrigerator Inner Door

<b>No. of bottle shelves</b>	1
------------------------------	---

No. of door shelves with transparent cover 1

Number of adjustable door shelves 2

## Other Refrigerator features



Accessories  
MultiFlow

Egg tray  
Yes

Fan

Yes

## Freezer compartment features

Number of drawers 3

## Other Freezer features

Accessories 1 ice box

## Other technical features

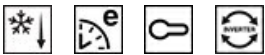

Functions display

Fast freezing, Fast cooling, ECO, Control lock, Temperature alarm, Cooling timer

Temperature alarm lamp

Yes

Door open alarm

Yes

Temperature Alarm

Yes

Type of temperature control

Electronic

No. of compressors

1

Refrigerant gas type

R600a

Type of compressor

Inverter

Foam agent

Cyclopentane

## Performance / Energy Label - Reg. 2019



Annual energy consumption 173 kWh/a

Energy efficiency class D

Airborne acoustical noise emission class B

Total net volume 248 l

Sum of the volumes of the frozen compartment(s) 62 l

Airborne acoustical noise emissions 34 dB(A) re 1 pW

Temperature Rise Time 11 h

4 star - Freezing capacity 5.0 kg/24h

Climate class SN, N, ST

EI 80 %

Sum of the volumes of the chill compartment(s) and the unfrozen compartment(s) 186 l

## Electrical Connection







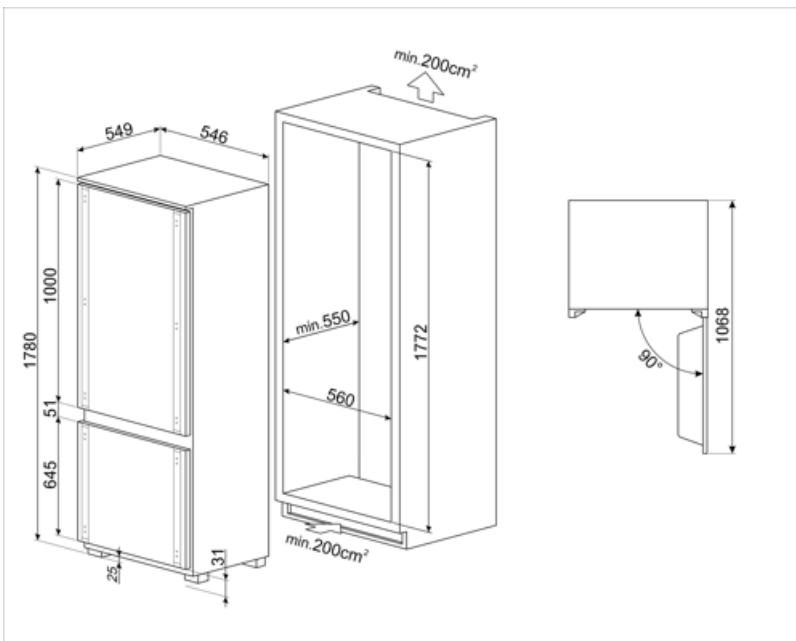



Electrical connection rating	140 W	Frequency (Hz)	50 Hz
Current	1.1 A	Power supply cable length	240 cm
Voltage (V)	220-240 V	Plug	(F;E) Schuko

## Logistic Information

Width	546 mm	Depth of the built-in niche	550 mm
Width of the built-in niche	560 mm	Height	1772 mm
Depth without handle	549 mm	Height of the built-in niche	1780 mm



## Symbols glossary

- |   |  |   |  |
|---|--|---|--|
|   | The automatic defrost system works by automatically defrosting at regular intervals eliminating the need to defrost altogether.            |  | Child lock: some models are fitted with a device to lock the programme/cycle so it cannot be accidentally changed.                                       |
|   | LCD display: to optimize performance and simplify the use of the appliance.  |  | Economical mode: Analyzes fridge functioning during the activation and optimizes the operating cycle in order to reduce power consumption.               |
|   | Ventilated: Forced distribution of cold air in the refrigerator compartment, which allows even temperature distribution within the fridge. |  | Fast freezing: The fast freezing function brings the temperature of the compartment down when activated a few hours prior to usage.                      |
|   | LED interior lighting: is a more energy efficient and long lasting way of illuminating the interior of the appliance.                      |  | Smeg's evolution towards more intelligent and eco-friendly models has led to the choice of Inverter technology, which significantly reduces consumption. |
|   | Multiflow Cooling System: the Multiflow ventilation system allows an even distribution of cool air around the fridge cabinet.              |  | Built-in niche   |
|  | Energy efficiency class D  |   |  |